



Wooden sash of the mid 1830s with decorative margin lights

- draughtproofing, secondary glazing, and even traditional shutters and heavy curtains improve energy efficiency and reduce noise transmission
- it is possible to hinge a bottom sash to allow easy and safe cleaning
- modern locking devices are available to deter intruders and to restrict opening, for the safety of children

If sash windows need repair, it may well be sensible to upgrade them at the same time.

Surveying and assessment

A detailed annual survey and analysis is helpful to determine the extent and precise causes of any deterioration, and the category of renovation involved. You can do this yourself or employ a professional. If you choose to do it yourself, it is best to record your observations on a sketch elevation of the window.

Look for the following key points

- any signs of structural movement which is deforming the opening and damaging the window. (Remember that some signs of movement are so old that they have long since been stabilised or repaired, leaving the window in working order: its deformation expresses its age and character.)
- evidence that the pointing of the frame to the wall opening is cracked, loose, or missing, allowing moisture to penetrate the sash-box timbers.
- sashes that do not move properly, or at all. This may be due to overpainting of the joinery, stop beads that have been fitted too tightly, pulley wheels that have seized up because of overpainting or lack of lubrication, broken sash cords, swelling due to water absorption (see below), or inadequate lubrication between the sash and the pulley linings
- evidence of water absorption, indicating possible wood decay (wet rot). The signs to look for are
 - interior paint failure caused by condensation
 - exterior paint failure
 - opening of the frame joints
 - degradation of the wood surfaces (where paint has flaked off) or depressions in the wood surface
 - cracked, loose, or missing putty
 - standing water, especially on the sills

It is important to ensure that water does not enter crucial joints, such as the lower parts of sills or jambs,

where deterioration most often occurs. Joints should be kept tightly closed: in addition, it is helpful to seal end grains with paint before assembly. You should also watch for any putty failure (which encourages water to sit on the flat surfaces of the glazing bars and meeting rails) and for deterioration in the protective paint finish.

If the timber has been affected by rot, the underlying surface will be soft and fibrous. The wood's moisture content can be measured with a meter: repeated readings of over 20% indicate that wood decay is likely unless steps are taken to dry out the area at risk and to eliminate the cause of the dampness.

It is easy to repair affected areas by cutting out the rotting wood and replacing it with a piece of sound, treated timber. (See *The repair of wood windows*, published by the Society for the Protection of Ancient Buildings, for details of this type of treatment.) Epoxy resins are sometimes used as a substitute for treated wood in these patch repairs. However, it is important to paint over the repaired area as soon as possible, as resin degrades in ultra-violet light.

Useful addresses

The British Woodworking Federation
82 New Cavendish Street
London W1M 8AD
0171 872 8210

The Building Research Establishment
Garston
Watford WD2 7JR
01923 664664

The Society for the Protection of Ancient Buildings
37 Spital Square
London E1 6DY
0171 377 1644

Timber sash windows



ENGLISH HERITAGE

History

Single-hung sash windows (where only the bottom frame moves and is supported by wooden gates or pins when open) were probably copied by the British from France some time in the mid-seventeenth century. The double-hung sash, however, appears to have been a British invention. This was an ingenious technological breakthrough that enabled a far more subtle and sophisticated system of ventilation to be achieved than was possible with the old, side-hung casement. It used a system of hidden, counterbalanced weights to allow both top and bottom sash frames to be moved independently. The earliest double-hung sash discovered so far dates from 1701; however, by 1720 double-hung sashes had spread only as far as Holland and the British and Dutch colonies.

Until the early eighteenth century sash frames were usually made of native oak or a similar hardwood. By 1700, oak was becoming rarer and thus more expensive, while softwoods from Scotland, the Baltic, and North America were more widely available. From the 1720s most sash joinery used deal, a generic term for pine or fir softwood.

As a precautionary measure against fire the 1709 Building Act required that the corners of a sash box frame be hidden behind the face of the brick or stone masonry and that 'no door or window frame of wood... shall be set nearer to the outside face of the wall than four inches'. In 1774 this distance was increased to nine inches, and nearly all of the frame had to be hidden behind the face of the wall. While this legislation was initially only applicable to London, within a few years its provisions were being taken up throughout Britain and America.



A late Georgian sash window of c1800, partly restored, from Greenwich, London

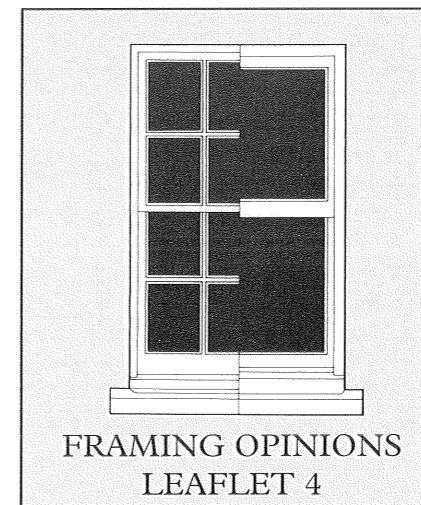

FRAMING OPINIONS
LEAFLET 4

By 1730 segmentally arched windows had largely been replaced by square-headed varieties that were cheaper to make. The glazing patterns inserted into these frames often took the form of six panes over six, although this was by no means the rule. Nor were the dimensions of each pane necessarily dependent on the principle of the golden section: in some cases,

individual panes were broader than they were tall. The overall size of the window was, nevertheless, always kept in strict proportional harmony with the rest of the facade, in accordance with Palladian theory.

Early glazing bars were thick and robust, to support and protect the fragile glass. Most late seventeenth- and early eighteenth-century examples were based on the ovolo, or quarter-circle moulding. As glass technology improved and glass became stronger, glazing bars became increasingly slender, with pointed (gothic) and lamb's-tongue mouldings becoming very popular. By 1820 some glazing bars were only 12.5mm wide (although, to provide lateral strength, these could be up to 38mm deep).

As with so many elements of the Georgian house, glazing-bar patterns and profiles varied according to the social status of the window. Thus, for example, basement or attic windows, used only by servants, were often fitted with old-fashioned, obtrusive ovolo glazing bars and inferior-quality glass.

With the introduction of cheap, strong plate glass in the 1830s glazing bars became less necessary and views became accordingly less cluttered. By 1850 many sash-window frames had no internal glazing at all. However, the great weight of these frames and the absence of any internal supports necessitated the introduction on the upper frame of sash horns, extensions of the stiles which helped to strengthen the vulnerable joints at either end of the meeting rail.

During the early eighteenth century white or stone-colour (white broken with yellow ochre and a little black) oil paint appears to have been almost the only finish used for painting sash windows. Only the wealthiest homes could afford more ostentatious finishes: by 1740 the window joinery at Chatsworth, Thoresby Hall, Holkham Hall, and Wentworth Woodhouse was gilded with real gold leaf. By 1770 more modest homes were beginning to experiment with alternatives: green, grey, brown, black, and graining. These dark colours were particularly popular against light-coloured

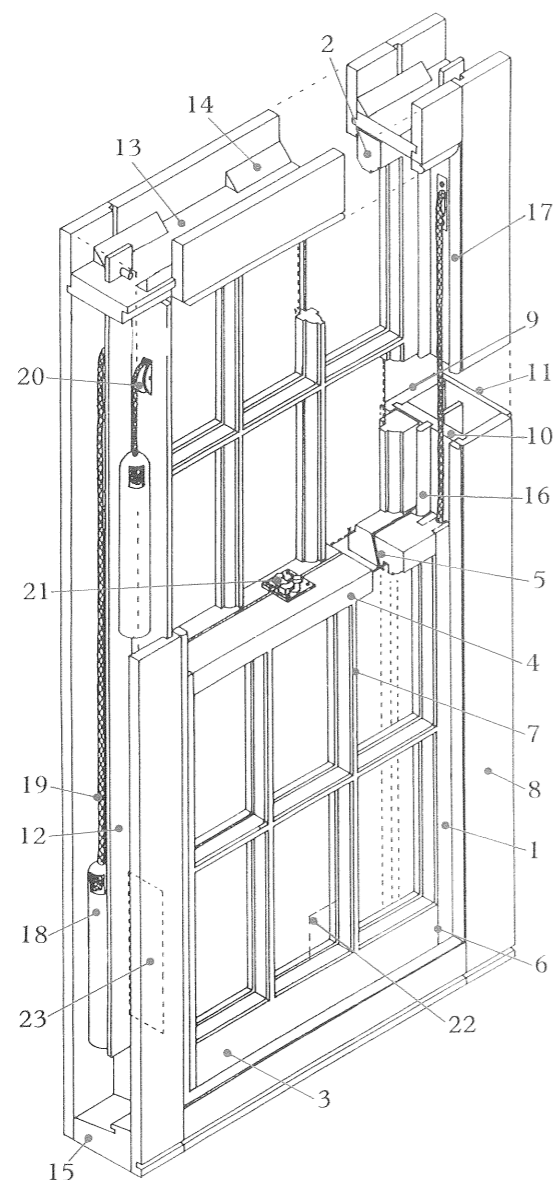

- 1 Vertical stile
- 2 Top rail
- 3 Bottom rail
- 4 Meeting rail
- 5 Bevelled face
- 6 Through mortice and tenon joint
- 7 Glazing bar
- 8 Inner lining
- 9 Outer lining
- 10 Pulley lining
- 11 Back lining
- 12 Parting slip
- 13 Soffit lining
- 14 Triangular fixing block
- 15 Cill
- 16 Parting bead
- 17 Stop bead
- 18 Counter weight
- 19 Sash cord
- 20 Pulley wheel
- 21 Sash fastener
- 22 Single sheet glazing held in place with sprigs and putty
- 23 Access pocket

stucco or stone facades. During the 1820s John Nash stipulated that the sashes of his stuccoed Regent's Park development were to be repainted every four years with oak graining, and analysis has recently confirmed the use of black for sashes at Sir John Soane's London home in the 1820s. By the end of the Georgian period green was very commonly used for more rustic homes, but white was still held to be the most appropriate colour for grander dwellings. However, by the middle of the century purple-brown paint (first recorded as early as 1803) was popular for window joinery.

Timber quality

The science of timber preservation is relatively new (the first list of preservatives was published in the *Encyclopaedia Britannica* in 1810). However, many sash windows of the eighteenth and nineteenth centuries continue to provide excellent

service. In contrast, some of the new timber windows of the 1960s and 70s are already deteriorating. Part of the reason for this situation lies in the choice of timber. Heartwood, from the centre of the tree, is naturally durable, and should always be preferred. Conversely, sapwood (the outer layers of the trunk) is permeable and contains sugars and starch that provide an excellent food source for fungi; it is therefore unsuitable for external joinery. Since 1945 it has been common practice to use poor-quality wood for many joinery tasks. It is therefore important to retain old joinery wherever it is sound, or, if repair or replacement is necessary, to ensure that the wood chosen is heartwood or, at very least, well-treated sapwood. It is not true that all modern softwood is low-grade: British, Scandinavian, and North American softwood from farmed, properly managed sources can still

last for decades and even centuries, particularly if treated before use.

When repairing window joinery always deal with the source of the problem, such as water ingress, first. If you need to apply preservative treatments these can be brushed on to the affected area after the decayed wood has been cut out. A more sophisticated method is to pressure-inject organic, solvent-based preservative into the timber through non-return valves, which are later filled. This is best done by a specialist and is not really economical for fewer than five windows. The insertion of preservative rods containing water-soluble chemicals (usually boric acid) which diffuse into the surrounding timber is also highly effective, but again is best carried out by an experienced person.

Repair and rehabilitation

A recent survey indicated that, on average, only 5% of timber in windows that were being replaced was affected by decay. Yet a 1991 Gallup Poll revealed that 46% of homeowners replaced wood windows because of 'rotten timber', and only 20% to reduce draughts and heating bills.

There are no inherent defects in the original design of the sash window, an extremely sophisticated piece of technology that has lasted, with minor modifications, for 350 years. It is also quite feasible to apply modern repair and maintenance techniques to our stock of existing sash windows. Therefore whenever possible original sash windows should be repaired rather than replaced. Permanent repair of a window may be less expensive than wholesale replacement, and no facsimile can be other than new work. It is also possible to bring original windows up to modern environmental standards without harming any features of historical value.

It is important to remember that where necessary:

- permanent repairs can be made using appropriate materials and timber preservatives
- the use of modern paints and methods can lengthen the time between redecorations

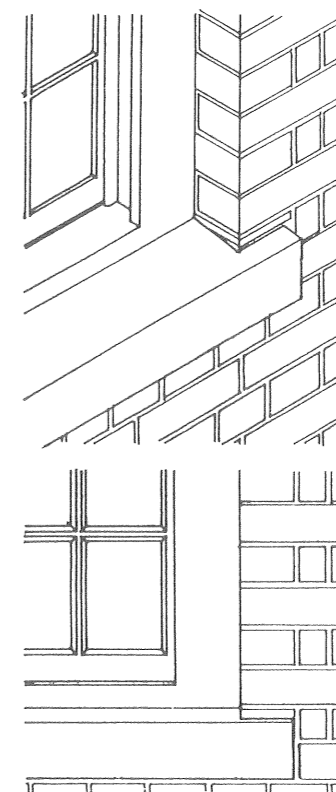

Traditional sash windows fixed 100mm (4 inches) back from the face of the external wall in accordance with the London Building Act of 1709

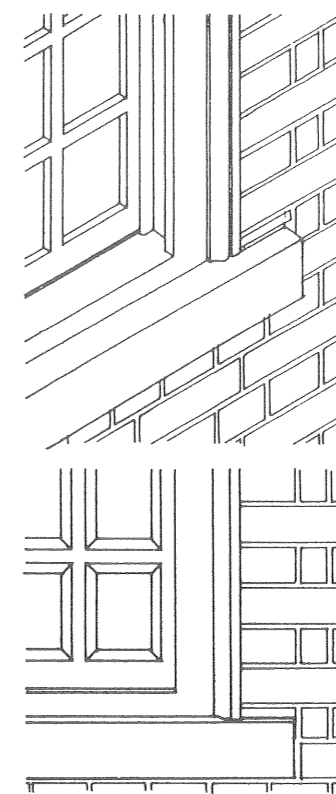

Traditional early sash window placed close to the external wall face with architrave used to mask the junction of the outer lining to the wall, an early detail but sometimes found in timber-framed buildings

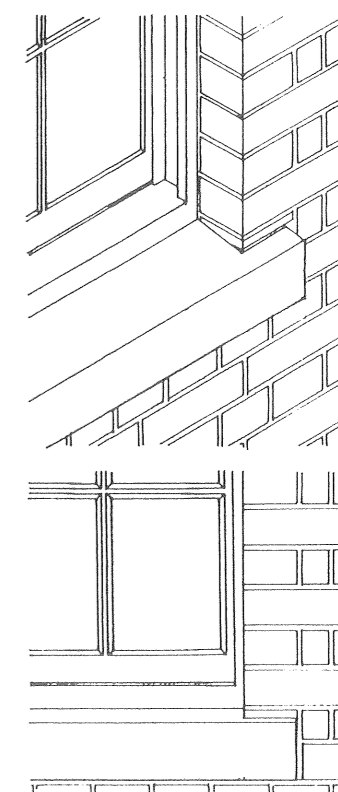

Traditional sash window, the linings fixed behind the masonry in accordance with the London Building Act of 1774

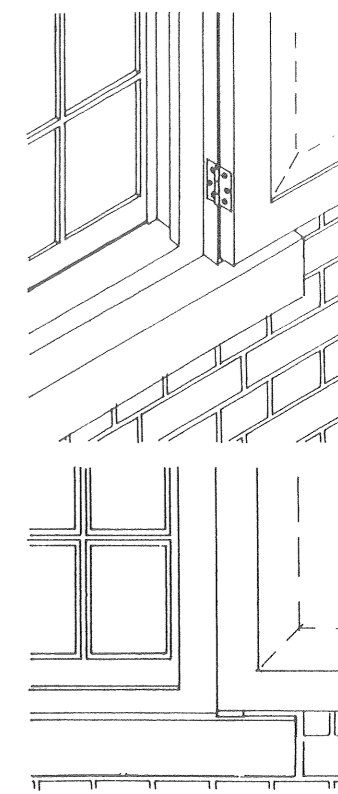

Traditional later sash window fixed slightly further back from the face of the wall to take a shutter